

CFD SIMULATION OF THE MUST FLOW IN A HYDROCYCLON

SIMULAREA CFD A CURGERII MUSTULUI ÎNTR-UN HIDROCIKLON

BĂETU M.¹, CÂRLESCU P.¹, ROȘCA R.¹, FILIMON R.²,
RITTNER T.¹, ȚENU I.¹

e-mail: itenu@uaiasi.ro

Abstract. *The hydrocyclone is an equipment for clarification and separation of the solid particles, in suspension in a liquid, based on the density difference. The flow description in a hydrocyclone is much more complex compared to a cyclone for gaseous dispersions, as it appears three liquid-gas-solid components (the appearance of the air core), although the overall separation mechanisms are similar. Over time, many experiments have been carried out to determine the flow in a hydrocyclone. The proposed experimental methods are expensive and difficult to implement in technical terms, being limited to a dispersed liquid phase. Given these deficiencies, in the last two decades, have been developed models of fluid flow dynamics (CFD) based on flow fundamentals. The paper aims is to CFD simulate the flow of must during the working process of a hydrocyclone.*

Key words: CFD simulation, must, hydrocyclone

Rezumat. *Hidrociclonul este un aparat de clarificare sau de separare a particulelor solide, aflate în suspensie într-un lichid, pe baza diferenței de masă volumică. Descrierea curgerii într-un hidrociclon este mult mai complexă comparativ cu un ciclon pentru dispersii gazoase, deoarece apar trei componente lichid-gaz-solid (apariția nucleului de aer), deși mecanismele globale de separare sunt similare. În decursul timpului, au fost realizate multe experimente pentru a determina curgerea într-un hidrociclon. Metodele experimentale propuse sunt costisitoare și dificil de aplicat din punct de vedere tehnic, fiind limitate la o fază lichidă dispersată. Ținând cont de aceste deficiențe, în ultimele două decenii, au fost dezvoltate modele de dinamica curgerii fluidelor (CFD) bazate pe fundamentele curgerii. Lucrarea are ca scop simularea CFD a curgerii mustului din struguri în timpul procesului de lucru al unui hidrociclon.*

Cuvinte cheie: simulare CFD, must, hidrociclon

INTRODUCTION

Simultaneously with the experimental efforts, different analytical models have been established in order to control and establish the flow characteristics of a hydrocyclone (Nageswararao *et al.*, 2004; Plitt, 1976; Chen *et al.* 2000). However, the models have limited applicability due to empiricism and difficulty in solving.

Given these deficiencies, in the last two decades, have been developed models of fluid flow dynamics (CFD) based on flow fundamentals. Boysan *et al.*

¹ University of Agricultural Sciences and Veterinary Medicine Iasi, Romania

² Research - Development Station for Viticulture and Winemaking Iasi, Romania

(1982) developed one of the first CFD models and showed that the k-ε turbulence model is not appropriate to simulate the flow in a hydrocyclone, resulting in tangential velocities and excessive and unrealistic turbulence viscosities. A number of papers suggest that the CFD models (Reynolds Stress Model - RSM) can improve the numerical accuracy of solutions (Sommerfeld and Ho, 2003; Schuetz *et al.*, 2004; Cârlescu, 2005).

MATERIAL AND METHOD

The accurate description of must flow in a hydrocyclone through simplified relations is more difficult to capture when velocity and pressure gradients are large in radial direction. In order to characterize the turbulent flow due to the needle rotation within the hydrocyclone, it is necessary to apply a suitable turbulence model. The RSM (Reynolds Stress Model) turbulence model describes with good accuracy the anisotropic turbulence.

The RSM model chosen proves to be a suitable turbulence model for hydrocyclone flow, although it requires higher computing resources compared to other simplified turbulence models (Wang and Yu, 2008; Xu *et al.*, 2009).

General mediated equations which govern the flow of an incompressible fluid can be written as follows:

- the continuity equation:

$$\frac{\partial \rho}{\partial t} + \frac{\partial}{\partial x_i} (\rho u_i) = 0 \quad (1)$$

- the momentum equation:

$$\frac{\partial}{\partial t} (\rho u_i) + \frac{\partial}{\partial x_j} (\rho u_i u_j) = -\frac{\partial p}{\partial x_i} + \frac{\partial}{\partial x_j} \left[\mu \left(\frac{\partial u_i}{\partial x_j} + \frac{\partial u_j}{\partial x_i} \right) \right] + \frac{\partial}{\partial x_j} (-\rho \overline{u_i u_j}) + \rho \cdot g_i \quad (2)$$

where: ρ - density of the liquid, μ - viscosity of the fluid, p - pressure, g - acceleration of gravity, $x_{i,j,k}$ - position considered as distance, t - time, u - velocity of the liquid.

The RSM model offers the possibility of modeling the flow in a much more rigorous manner than the k-ε or other models derived from it, for example taking the effect of curvature of the current lines due to turbulence at the top of the cyclone, as well as rapid changes by "deformations" that appear. The „Reynolds stress” model accurately reflects the potential of the complex flow field inside the hydrocyclone.

The geometry and components of the hydrocyclone used in CFD simulation are shown in figure 1.

Experimental and calculation contour conditions are required as numerical values for running the simulation (tab. 1).

Table 1

Experimental contour conditions

Pump speed n [RPM]	Velocity		Flow	
	u [m/s]	u _P [m/s]	Q _t [kg/s]	Q _P [kg/s]
1200	2.62	2.62	0.358	0.0372
1500	3.10	3.10	0.423	0.0441
1800	3.63	3.63	0.488	0.0508
2100	3.93	3.93	0.531	0.0553

Note: u- must velocity, u_p- particle velocity, Q_t - must flow, Q_p - particle flow

The must entering the hydrocyclone has the following physical parameters: must viscosity $\eta = 0.0018 \text{ Pa/s}$, must density $\rho_t = 1085 \text{ kg/m}^3$, particle density $\rho_p = 1130 \text{ kg/m}^3$.

The flow rate of particles supplied to the hydrocyclone in the simulation is 10 % of the flow rate of must, thus being in agreement with Fluent recommendations according to which it should not exceed 10-12% (ANSYS-Fluent User Guide, 2010).

Several experimental tests were performed in which the speed of the hydrocyclone feed pump was modified, thus resulting in several flows and input speeds.

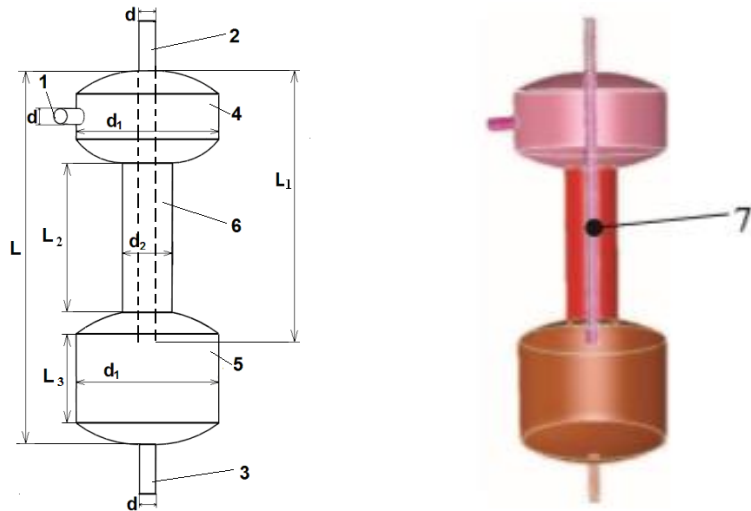

Fig. 1 Construction of hydrocyclone: 1 –suspension supply pipe; 2 – partially clarified liquid evacuation pipe; 3 – pipe for purging solid particles; 4 – superior body of centrifugation;5 – inferior body of sedimentation; 6 – intermediate body; 7- median inner pipe.

The partial sequence equation system, consisting of the continuity equation, the momentum equation, the „Reynolds stress” (RSM) and the turbulent energy dissipation of rate ϵ , was solved using a segregated solver (the equations are calculated so that the continuity equation is satisfied also locally) with the ANSYS - FLUENT V 6.3.26 software. The software is based on the finite volume method, which includes a differential formulation of all conservation equations in a control volume. In the control volume, a balance of the diffusion and convection fluxes is generated, reproducing the flow pattern, which is intensified by the turbulence described by the applied turbulent model, in this case the RSM model.

RSM model processing is complex and requires 50-60% more CPU time per iteration and approximately 15-20% more memory than the $k-\epsilon$ simplified turbulence model. The simulation ran on a TYAN workstation (2XCPU-Intel Xeon 3,33GHz; RAM – 16 Gb DDR3).

RESULTS AND DISCUSSIONS

For the three variants of the must considered in this study, the nephelometric turbidity unit was measured at the beginning and at the end of the separation process. The speed variation threshold, due to the requirements of the machine manufacturer, was comprised between 1200 and 2100 rpm.

The processing results are presented in the form of velocity fields, Reynolds turbulence and current lines.

The representation of the speed field in fig. 2 shows an increase in the velocity of the must in the upper body where the field of the centrifugal forces prevails with the increase of the inlet flow of the must, and in the lower body the speed is maintained at a low level for the three flows introduced in the simulation.

The identification of the Reynolds number distribution field (fig. 3) shows qualitatively the turbulent regime. In the lower body of the hydrocyclone the Reynolds number has higher values, ranging from 978 to 1140 in the region of the clarified must outlet pipe of the sedimentation body.

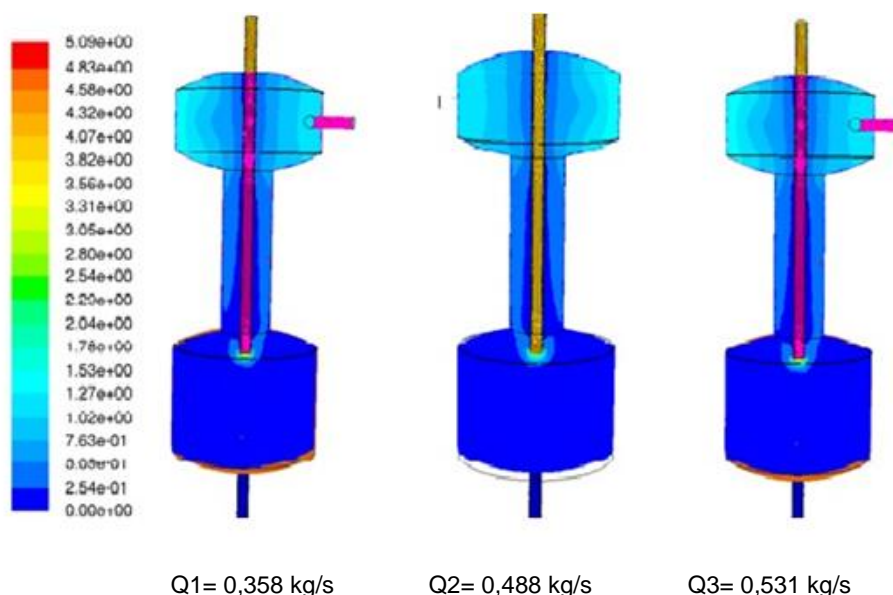

Fig. 2 Representation of the velocity field in hydrocyclone in the OY median plane, with purging pipe closed, at three different must supply flow rates

As a result of the fluctuating velocities that occur in the flow of must inside the hydrocyclone and of the significant variation of kinetic energy, it is difficult to perform the analytical calculation to determine the value of the Reynolds number in order to make a comparison with the simulated value. Such a calculation would lead to a qualitative alteration of the result. Therefore, CFD simulation of the must flow makes this calculation of Reynolds number much quicker and more accurate.

The flow lines in the lower body of the hydrocyclone (fig. 4), after the flow stabilization, concentrate towards the upper part of the lower sedimentation body, in the area of the drain must be clarified at a flow $Q_2 = 0.488 \text{ kg/s}$. At the rate of 0.358 kg/s and 0.531 kg/s respectively, the flow lines get close to the purge line.

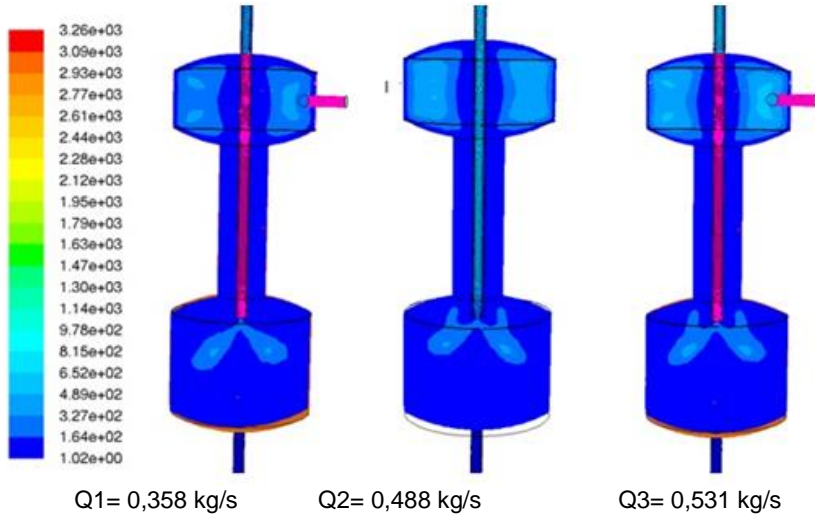

Fig. 3 Representation of the Reynolds turbulence field in hydrocyclone in the median plane OY, with purging pipe closed, at three different must supply flow rates

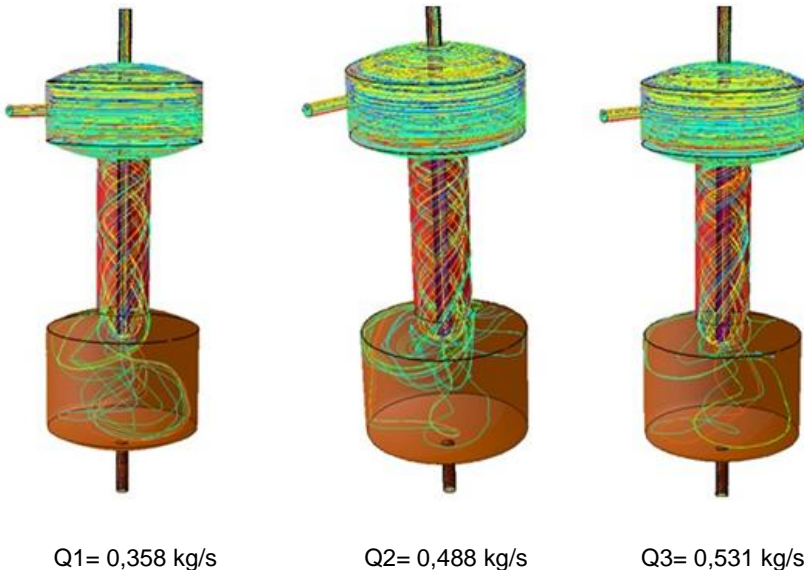

Fig. 4 Representation of the trajectory current lines in hydrocyclone with purging pipe closed, at three different must supply flow rates

CONCLUSIONS

1. Through the mathematical modeling and the CFD simulation (Computational Fluid Dynamic) of the must flowing in the hydrocyclone, one can observe how the flow regime follows inside the equipment, as well as the trajectories of the fluid current lines.

2. The advantages of using CFD simulation on a hydrocyclone are saving time and material resources, when using high performance programs and hardware (FLUENT, TYAN workstation).

3. By using the CFD simulation, which is based on experimental data new types of hydrocyclone may be designed, in order to obtain optimal variants to increase the efficiency of separation

REFERENCES

1. **Boysan F., Ayers W. H., Swithenbank J., 1982** – *Fundamental mathematical-modelling approach to cyclone design*, Trans. Inst. Chem. Eng., 60.
2. **Cârlescu P., 2005** – *Modelarea și simularea numerică a proceselor fizice industriale*. Edit. Performantica, Iași.
3. **Chen W., Zydek Chen W. N., Parma F., 2000** - *Evaluation of hydrocyclone models for practical applications*, Chem. Eng. J., 80.
4. **Nageswararao K., Wiseman D.M., Napier-Munn T.J., 2004** – *Two empirical hydrocyclone models revisited*, Miner. Eng.
5. **Plitt L.R., 1976** – *A mathematical model of the hydrocyclone classifier*, CIM Bull., 69.
6. **Schuetz S., Mayer G., Bierdel M., Piesche M., 2004** – *Investigations on the flow and separation behavior of hydrocyclones using computational fluid dynamics*, Int. J. Miner. Process., 73.
7. **Sommerfeld M., Ho C.A., 2003** – *Numerical calculation of particle transport in turbulent wall bounded flows*, Powder Technol., 131.
8. **Wang B., Yu A.B., 2008** – *Numerical Study of the Gas-Liquid-Solid Flow in Hydrocyclones with Different Configuration of Vortex Finder*, Chem Eng J., Vol. 135.
9. **Xu P., Wu Z., Mujumdar A.S., Yu A. B., 2009** – *Innovative Hydrocyclone Inlet Designs to Reduce Erosion-Induced Wear in Mineral Dewatering Processes*, Drying Tech., Vol. 27.
10. *** **2010** - *Ansys-Fluent – User Guide*.